

DESCRIPTION

A unidirectional microphone with a gooseneck shaft.
Use this microphone in conjunction with the ST-73A desk-top stand (option).

SPECIFICATIONS

Type	Moving coil microphone
Polar Pattern	Cardioid pattern
Rated Impedance	600 Ω, balanced
Rated Sensitivity	-54.5 dB (1 kHz, 0 dB=1 V/Pa)
Frequency Range	100 Hz - 10 kHz
Output Connector	∅21, 3-pin plug (BTS21P3B)
Finish	Microphone body, Gooseneck shaft: Gold, sparkling paint
Weight	465 g
Usable Stand	ST-73A (option) or ∅21 mm 3-pin socket
Accessories	∅21 3-pin receptacle (BTS21R3A).....1, M3×10 screw.....3, W3 washer.....3, SW3 spring washer.....3, M3 nut.....3

APPEARANCE

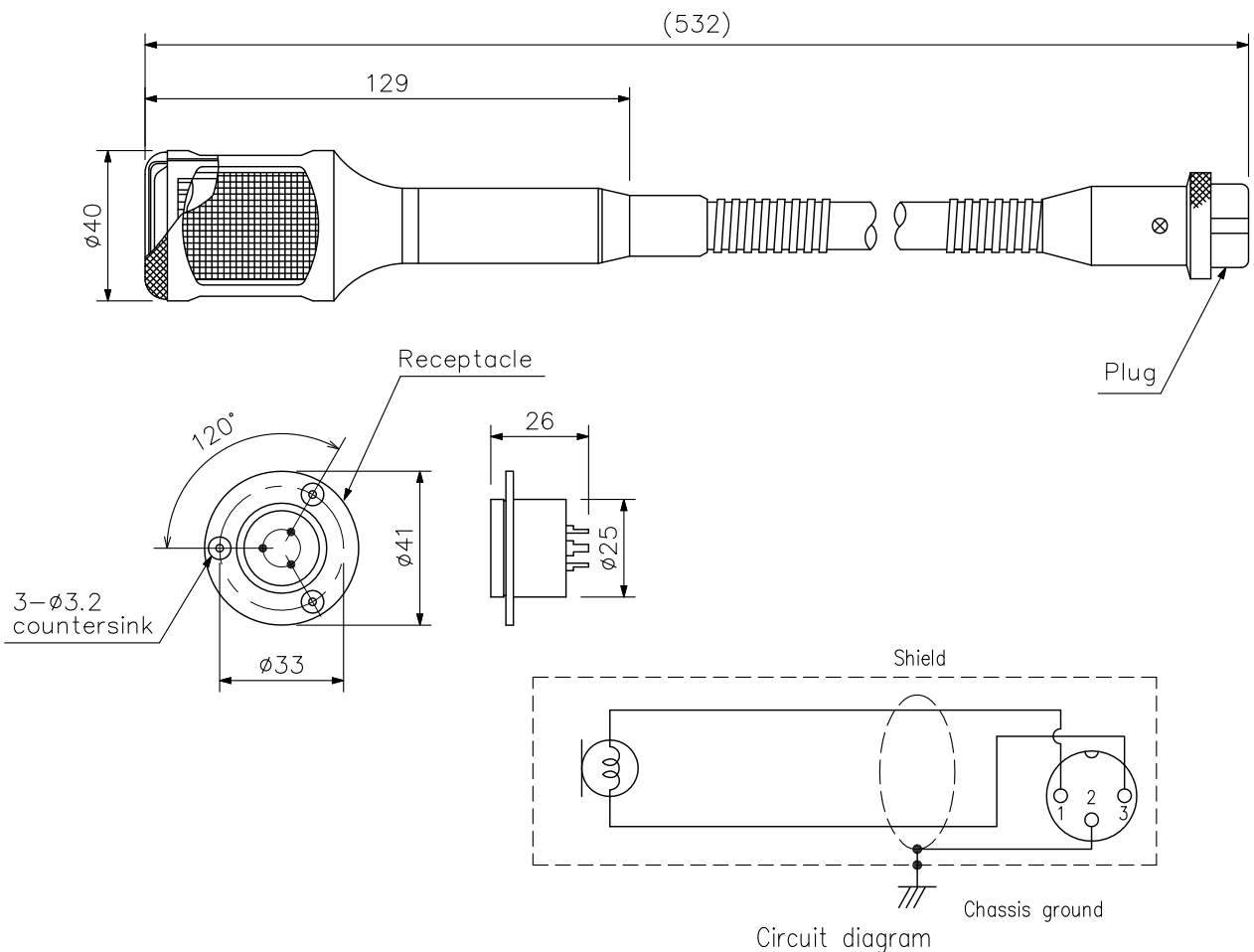

UNIT:mm SCALE:1/2

Note: Numerical values in parentheses are for reference only.